

Schematics	Revision	Date	Release Information
SRT-96B-MAIN-IOT-NBIOT-STM-MP157	1.0	OCT 2018	first version release
	1.1	SEP 2019	second version release
	1.2	OCT 2019	Changing Stackup

01

- 01** Revision History
- 02** Block Diagram
- 03** DXF
- 04** Stuck Up
- 05** 96Board Expantion Connector
- 06** STM-MP157-MPU-I/O
- 07** STM-MP157-MPU-POWER
- 08** PMIC
- 09** DDR3
- 10** NAND-FLASH
- 11** SD-CARD
- 12** USB-PORTS
- 13** Peripherals (LEDS, JTAG)
- 14** MODEM - 1
- 15** MODEM - 2
- 16** MISC

Silk:

Stinger96
SRT-PCB-01001
REV 1.2

Shiratech Solutions	Revision History			
	SRT-96B-MAIN-IOT-NBIOT-STM-MP157			
Drawn By Moshe Arad	Size A3	CAGE Code <Cage Code>	DWG NO A	Rev 1.1
Tuesday, November 05, 2019	Scale		Sheet	1 of 16

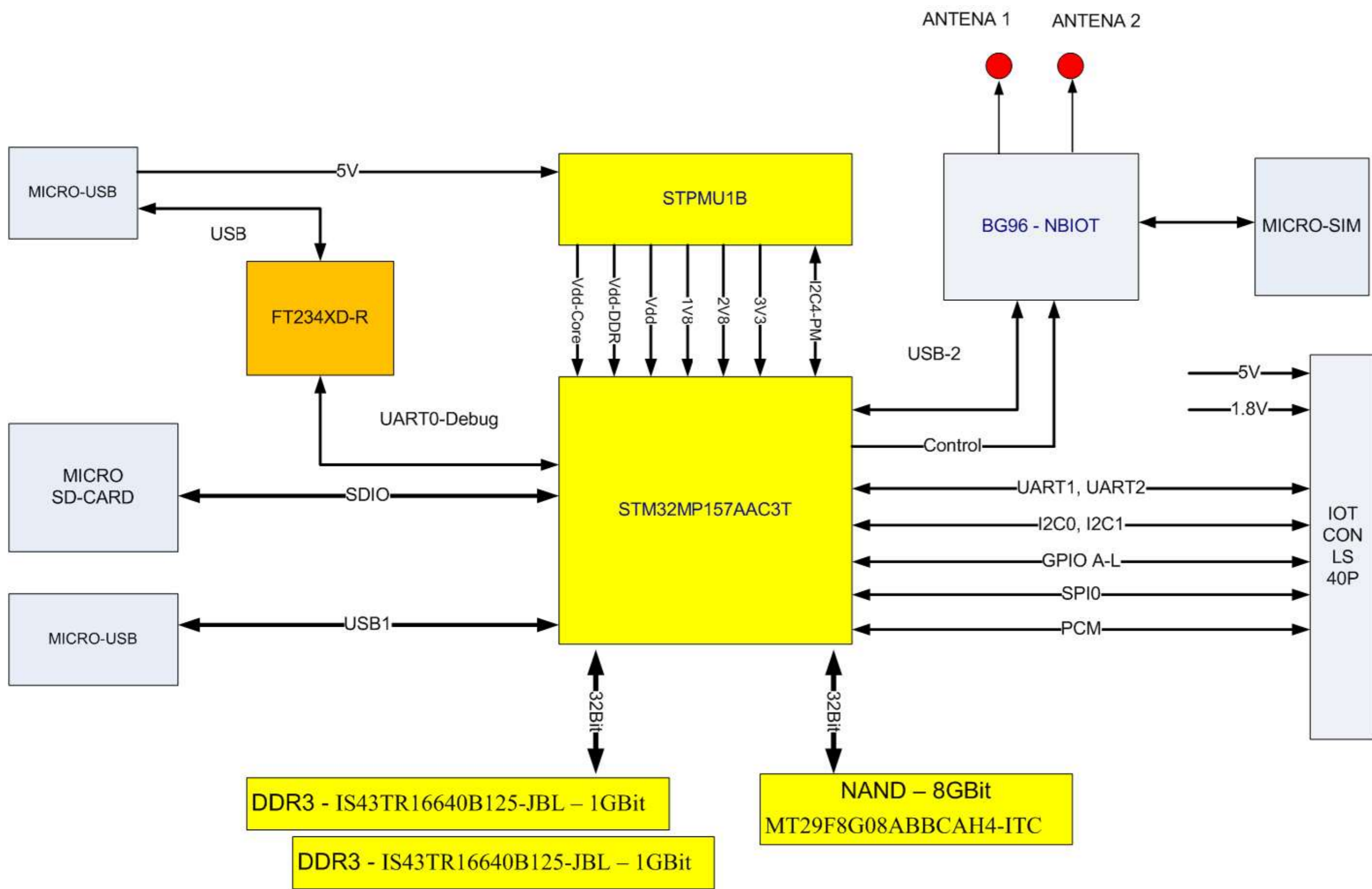

Shiratech Solutions	Block Diagram			
	SRT-96B-MAIN-IOT-NBIOT-STM-MP157			
Drawn By Moshe Arad	Size A3	CAGE Code <Cage Code>	DWG NO A	Rev 1.1
Tuesday, September 24, 2019	Scale	Sheet 2 of 16		

SRT-96B-MAIN-IOT-NBIOT-STM-MP157

03

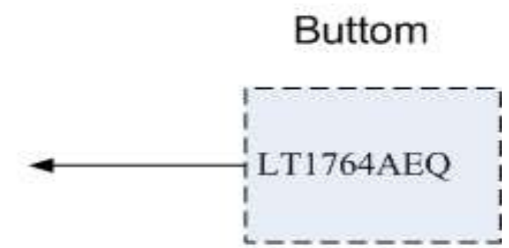
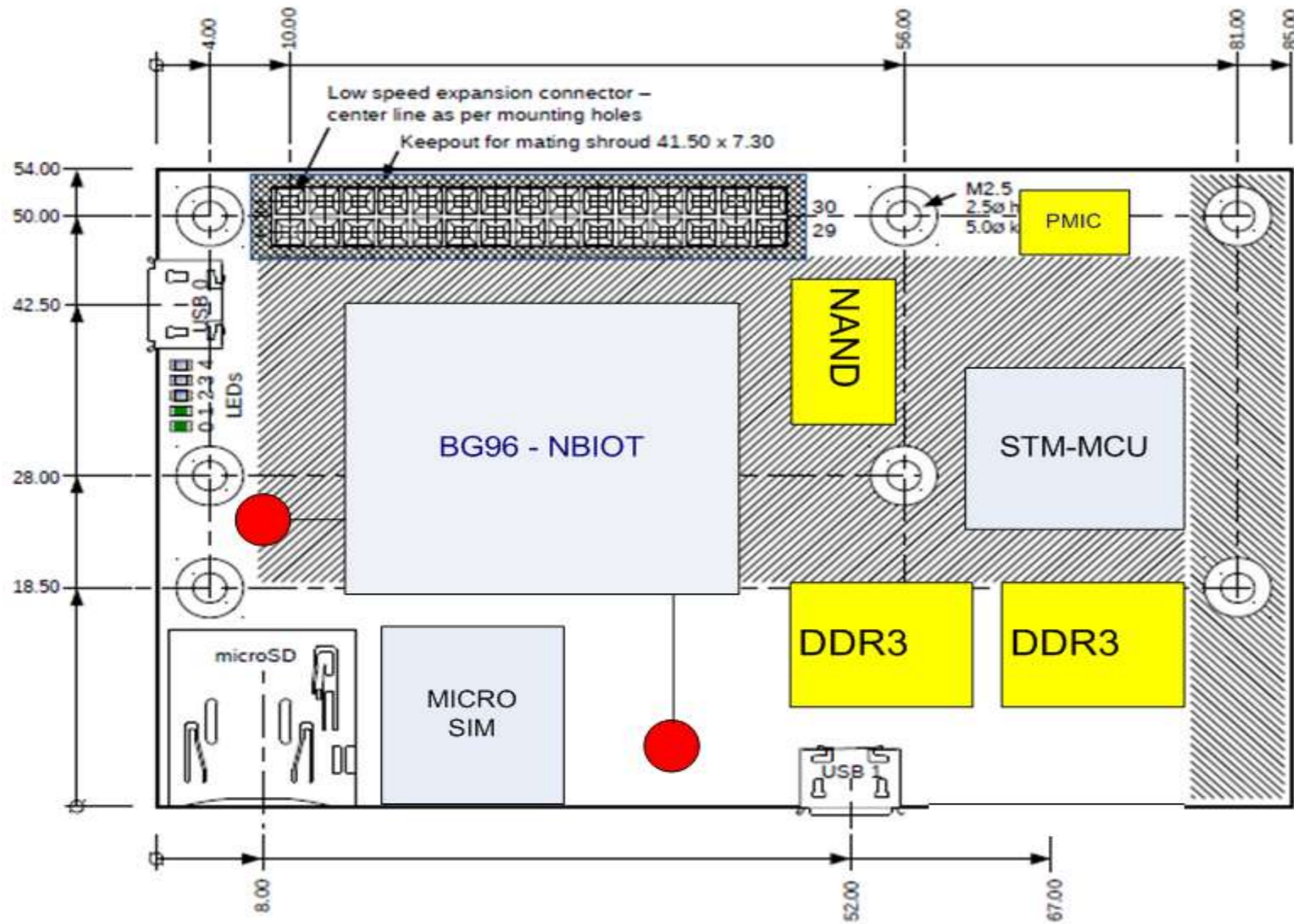

● ANTENNA

Shiratech Solutions	DXF		
	SRT-96B-MAIN-IOT-NBIOT-STM-MP157		
Drawn By Moshe Arad	Size A3	CAGE Code <Cage Code>	DWG NO A
Tuesday, September 24, 2019	Scale	Sheet 3 of 16	Rev 1.1

04

layer	name	cu thickness (mil)	dielectric thickness (mil)	line width base (mil)	differential space (mil)	er	Zo (ohms)	Zdiff (ohms)	
foils- Date:06/01/13 Customer: valens Boardname:10 layers				6		8	3.8	50.68710153	89.37827105
1 (coated microstrip)	pln	2.1		5		10	3.8	54.75657557	99.64842697
pp glass epoxy (tg 180)				4					
2 (ref. plane)	pln	1.4							
core glass epoxy (tg 180)					4.5	5	3.8	50.15743385	90.47649966
3 (offset stripline)	sig	0.7			4	7	3.8	52.99137943	100.0845077
pp glass epoxy (tg 180)				5		3.5	4.5		98.4
4 (ref. plane)	pln	1.4							
core glass epoxy (tg 180)					5.5		3.8	50.90751816	
5 (offset stripline)	sig	0.7			4	5.5	3.8	58.67816363	100.0605955
pp glass epoxy (tg 180)				14		3.5	4.5		100.88
6 (offset stripline)	sig	0.7			5.5		3.8	50.90751816	
core glass epoxy (tg 180)					4	5.5	3.8	58.67816363	100.0605955
7 (ref. plane)	pln	1.4			3.5	4.5			100.88
pp glass epoxy (tg 180)				5					
8 (offset stripline)	sig	0.7			4.5	5	3.8	50.15743385	90.47649966
core glass epoxy (tg 180)					4	7	3.8	52.99137943	100.0845077
9 (ref. plane)	pln	1.4			3.5	4.5			98.4
pp glass epoxy (tg 180)				4					
10 (coated microstrip)	sig	2.1		6		8	3.8	50.68710153	89.37827105
				5		10	3.8	54.75657557	99.64842697
		0.34004	1.27						
total thickness (including plating and solder mask) +/- 10%			1.61004						
impedance on the manufactured boards will be within +/- 10% of the values calculated above									
VIA SIZE									
LAYER	PAD	HOLE							
1-12	16	8							
1-2, 11-12	10	4							
2-3, 10-11	10	4							
3-10	16	8							

Shiratech Solutions	Stuck Up		
	SRT-96B-MAIN-IOT-NBIOT-STM-MP157		
Drawn By Moshe Arad	Size A3	CAGE Code <Cage Code>	DWG NO A
Tuesday, September 24, 2019	Scale	Sheet 4 of 16	Rev 1.1

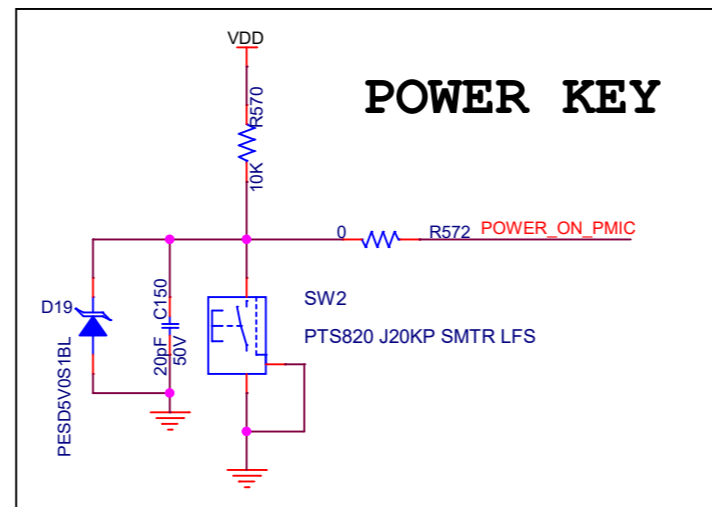
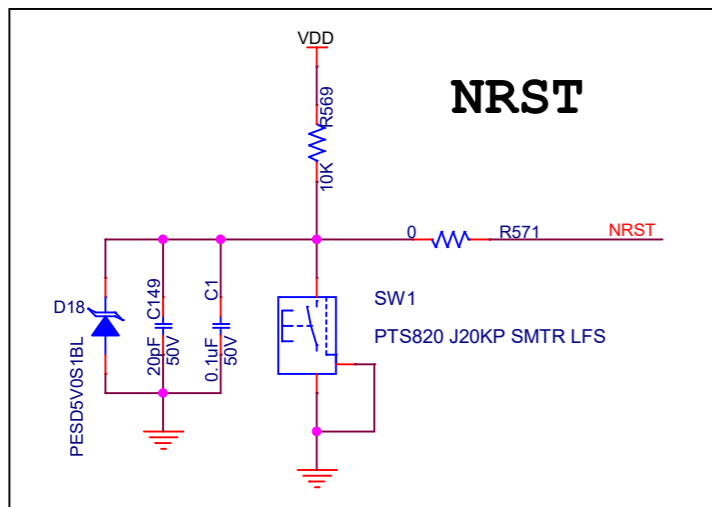

MATING - tmmh-120-05-f-dv-m-tr

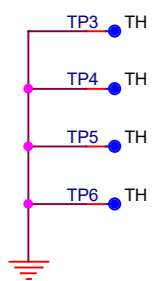
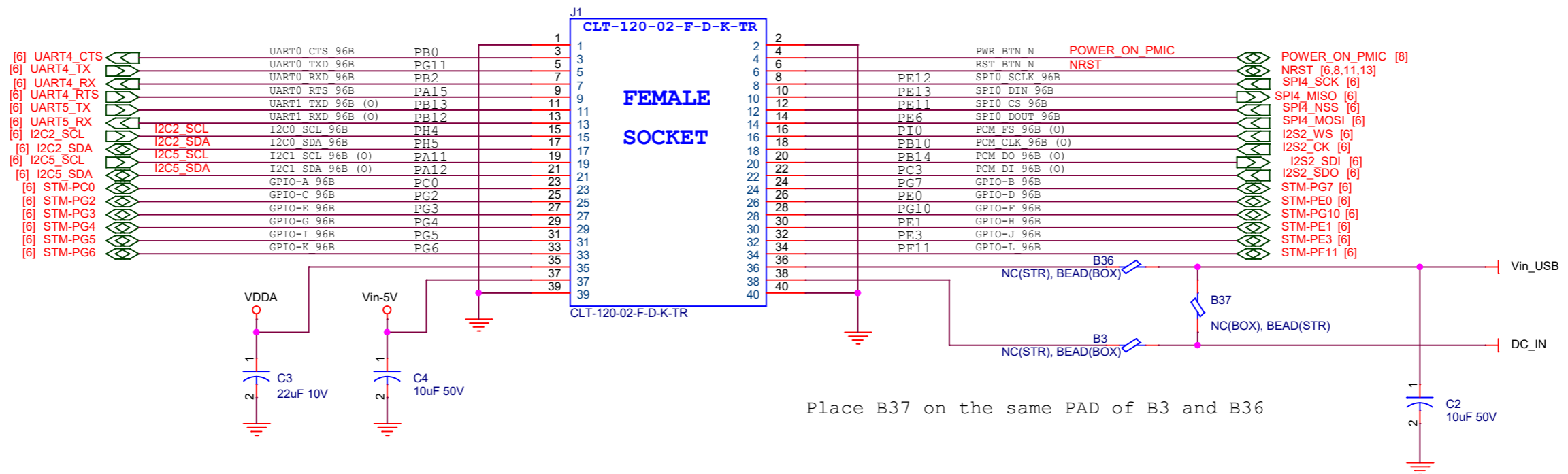

Place 4 TP's at the PCB corners

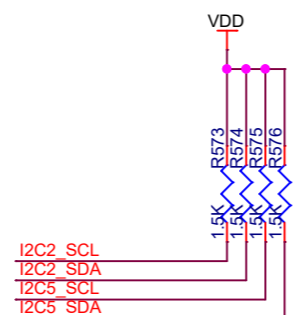

PCB REV 1.2
SRT-PCB-01001

Shiratech Solutions	96Board Expantion Connecto		
	SRT-96B-MAIN-IOT-NBIOT-STM-MP157		
Drawn By MoshA Arad	Size A3	CAGE Code <Cage Code>	DWG NO A
Tuesday, September 24, 2019	Scale	Sheet 5 of 16	Rev 1.1

06

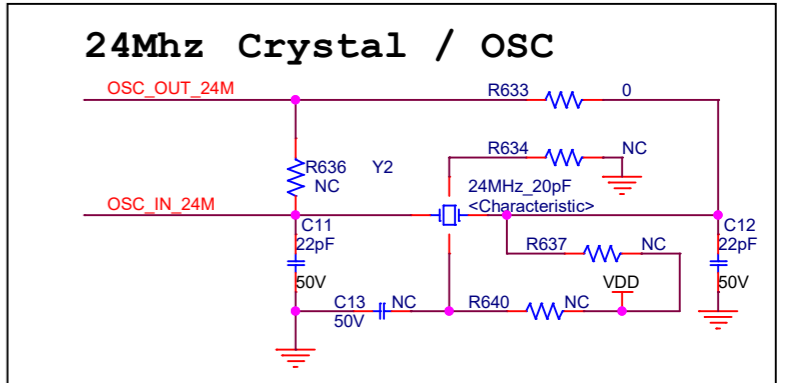
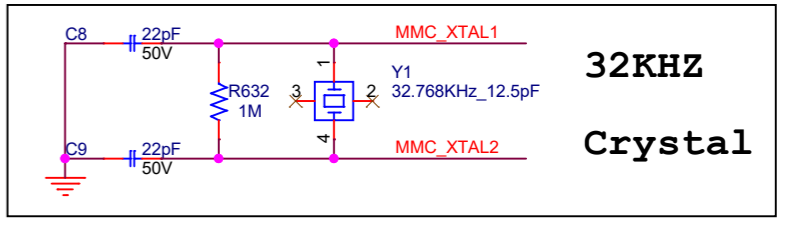
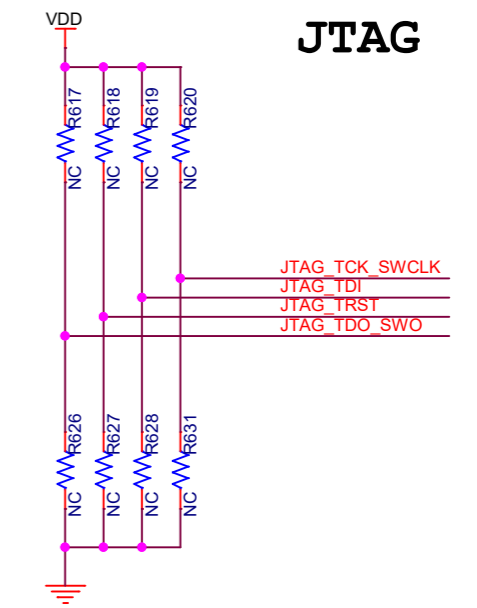
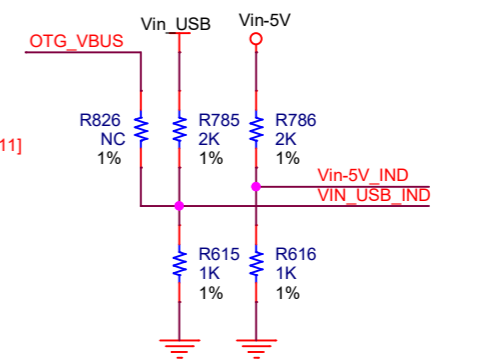
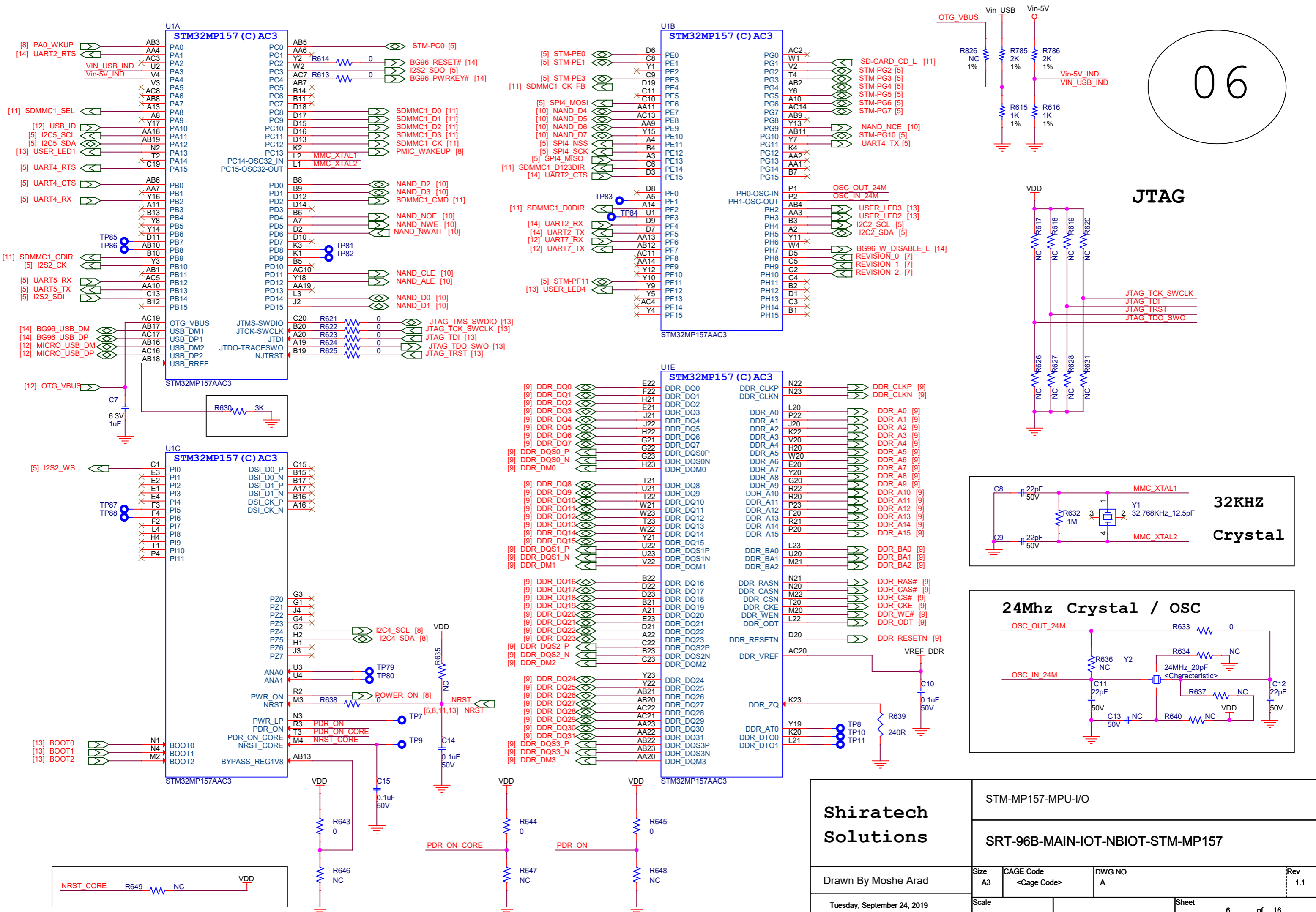

Shiratech Solutions		STM-MP157-MPU-I/O	
		SRT-96B-MAIN-IOT-NBIOT-STM-MP157	
Drawn By Moshe Arad	Size A3	CAGE Code <Cage Code>	DWG NO A
Tuesday, September 24, 2019	Scale	Sheet 6 of 16	Rev 1.1

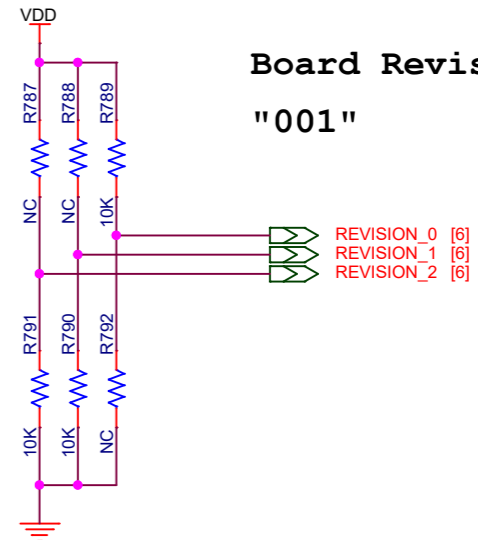
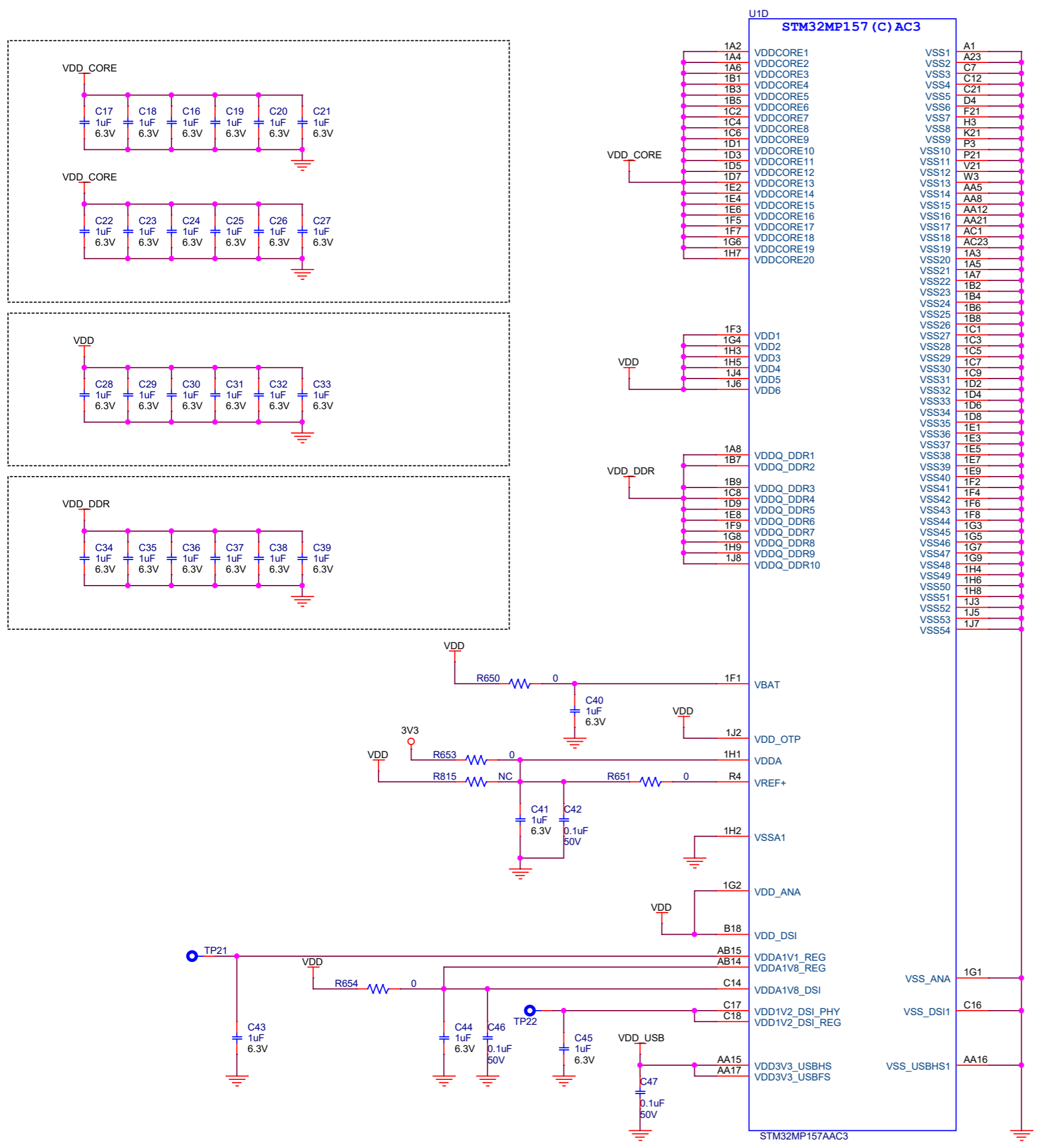

Shiratech Solutions	STM-MP157-MPU-POWER		
	SRT-96B-MAIN-IOT-NBIOT-STM-MP157		
Drawn By Moshe Arad	Size A3	CAGE Code <Cage Code>	DWG NO A
Tuesday, September 24, 2019	Scale	Sheet 7 of 16	Rev 1.1

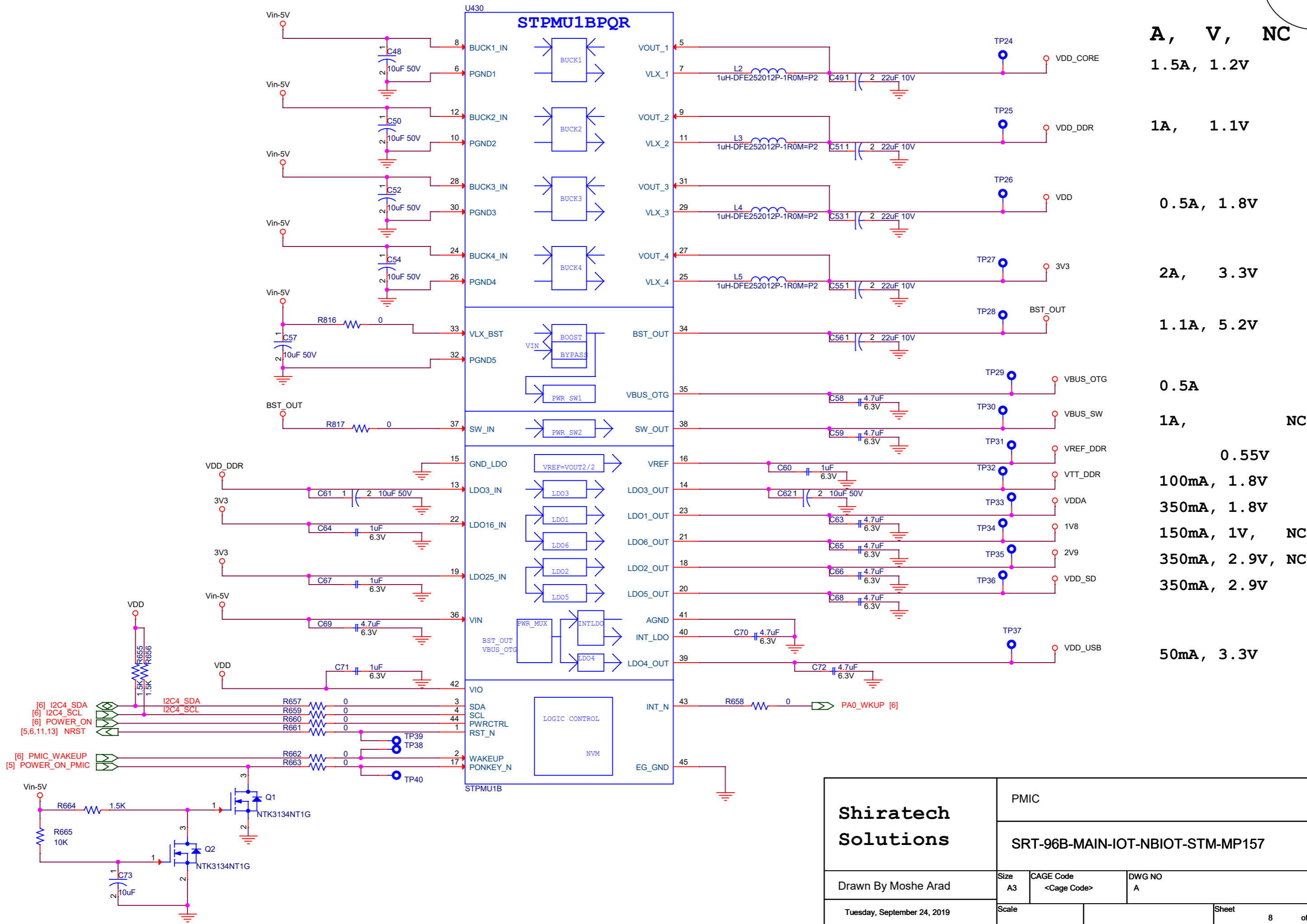

Output	Current (A)	Voltage (V)	NC
VDD_CORE	1.5A	1.2V	
VDD_DDR	1A	1.1V	
VDD	0.5A	1.8V	
3V3	2A	3.3V	
BST_OUT	1.1A	5.2V	
VBUS_OTG	0.5A		
VBUS_SW	1A		NC
VREF_DDR		0.55V	
VTT_DDR	100mA	1.8V	
VDDA	350mA	1.8V	
1V8	150mA	1V	NC
2V9	350mA	2.9V	NC
VDD_SD	350mA	2.9V	
VDD_USB	50mA	3.3V	

Shiratech Solutions	PMIC		
	SRT-96B-MAIN-IOT-NBIOT-STM-MP157		
Drawn By Moshe Arad	Size A3	CAGE Code <Cage Code>	DWG NO A
Tuesday, September 24, 2019	Scale	Sheet 8 of 16	Rev 1.1

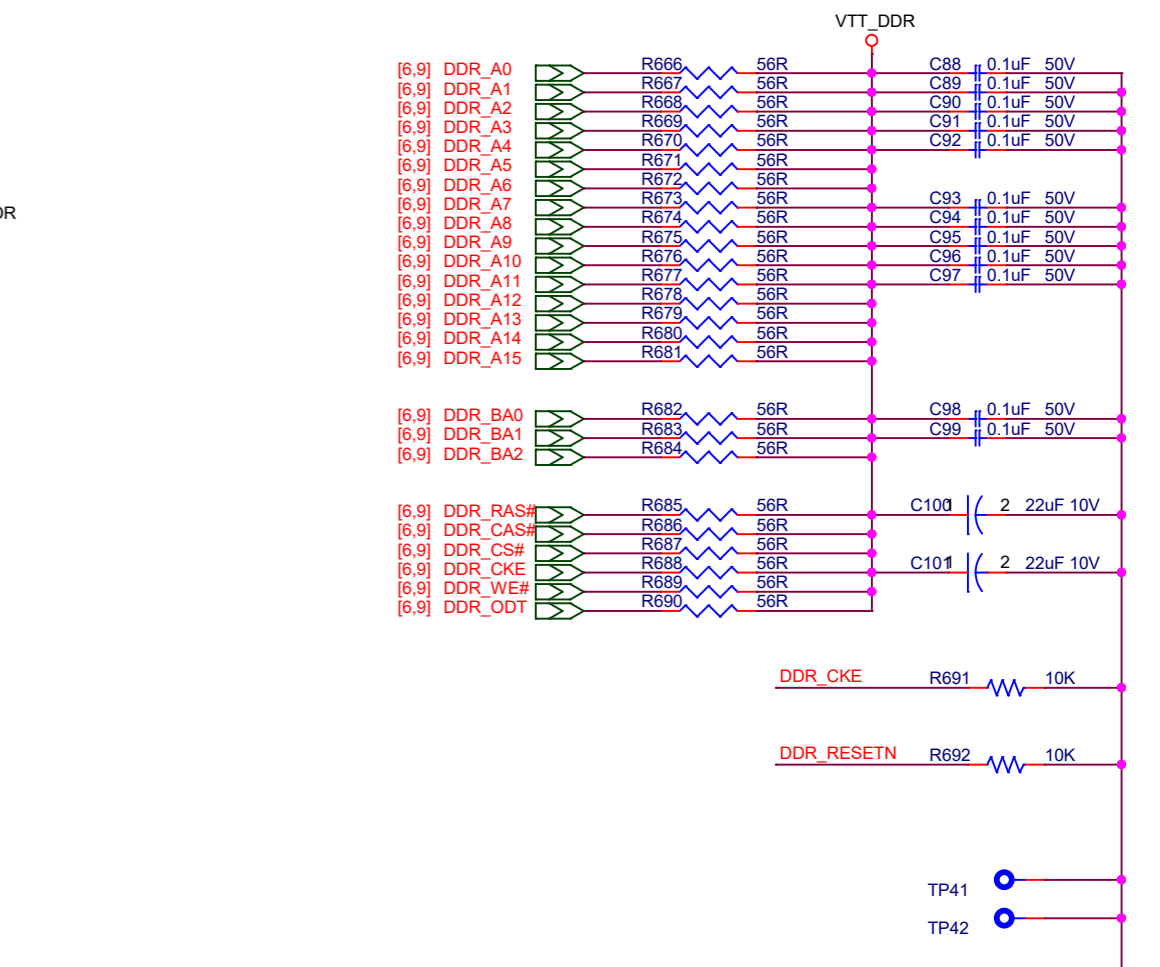
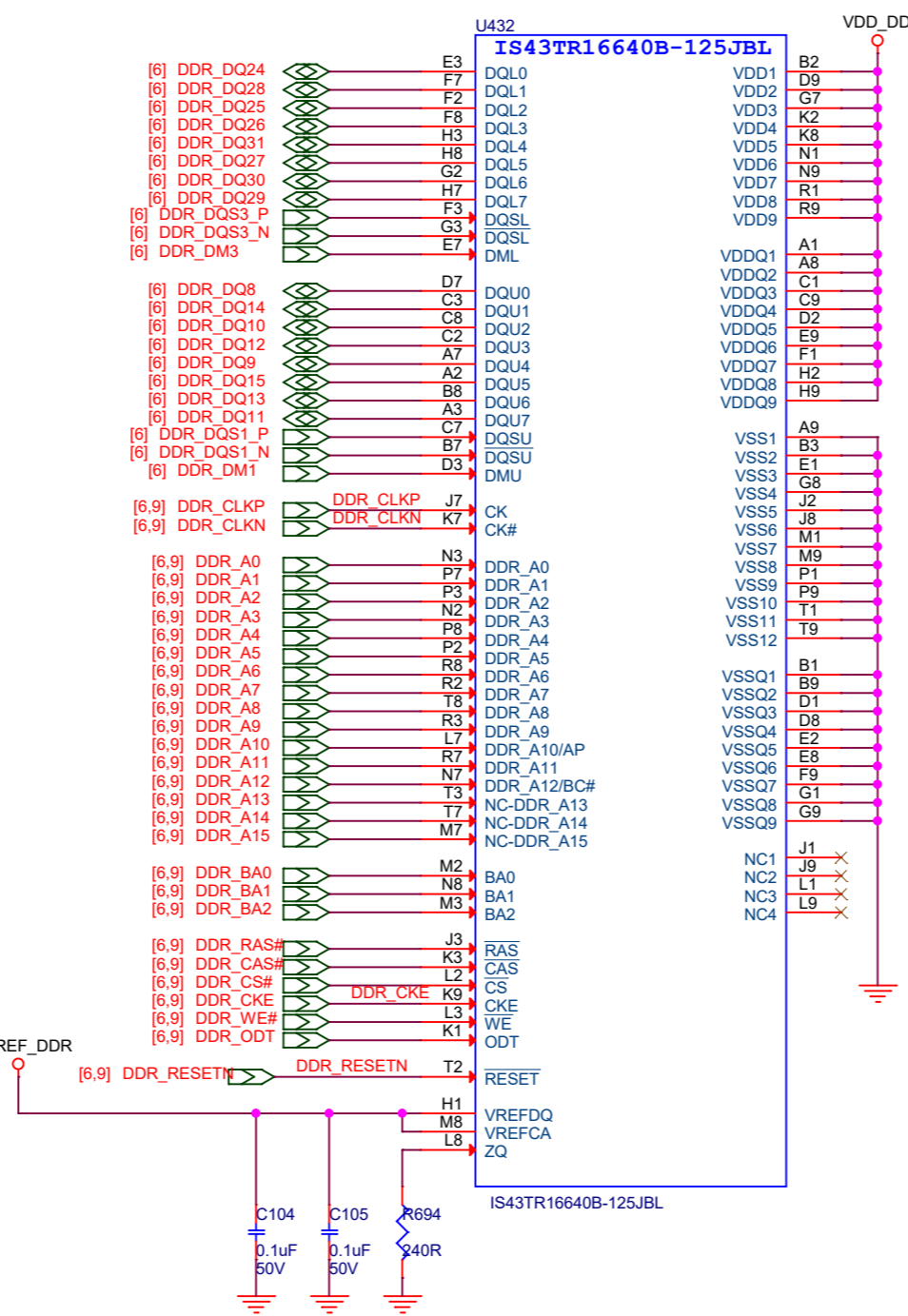
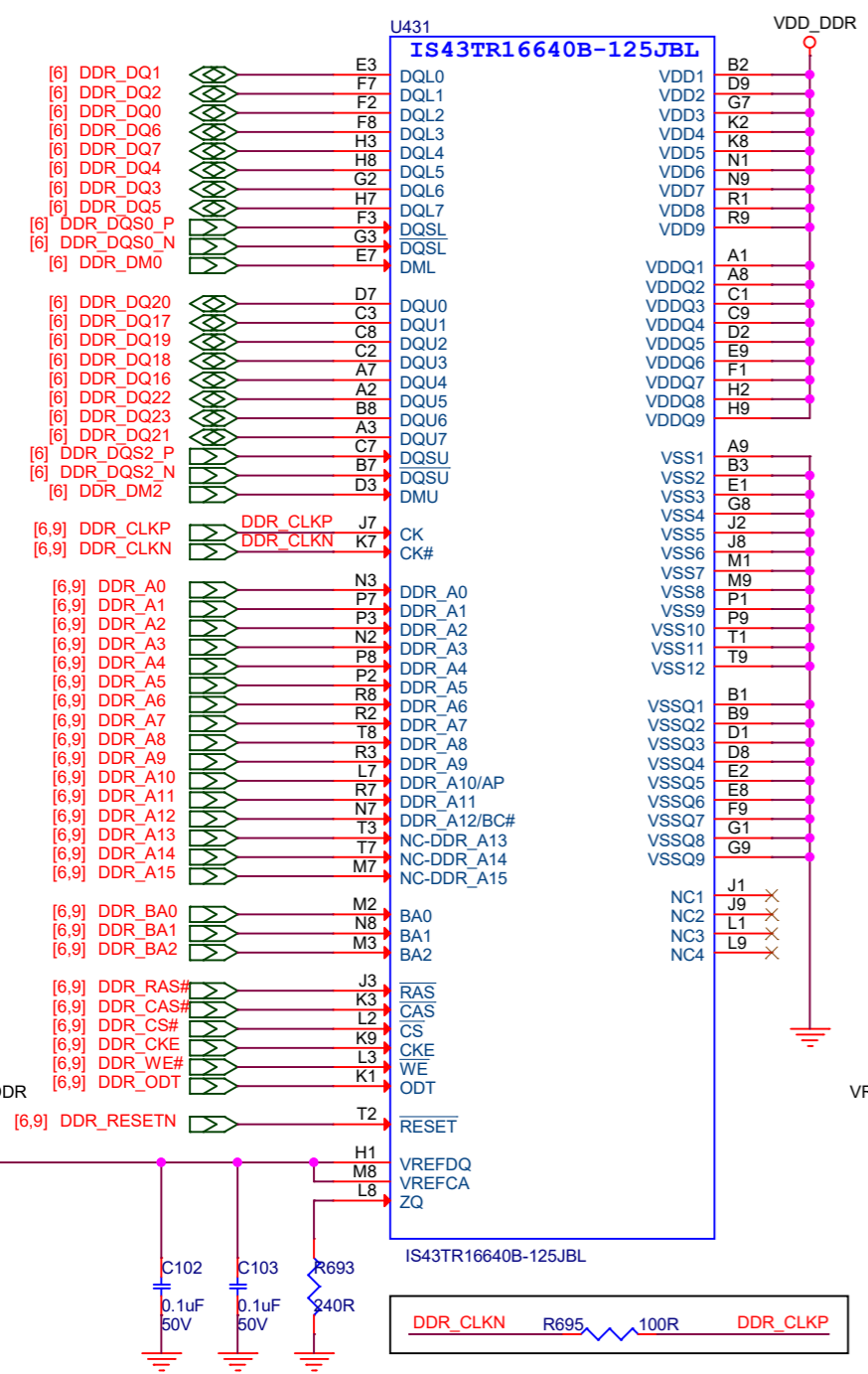
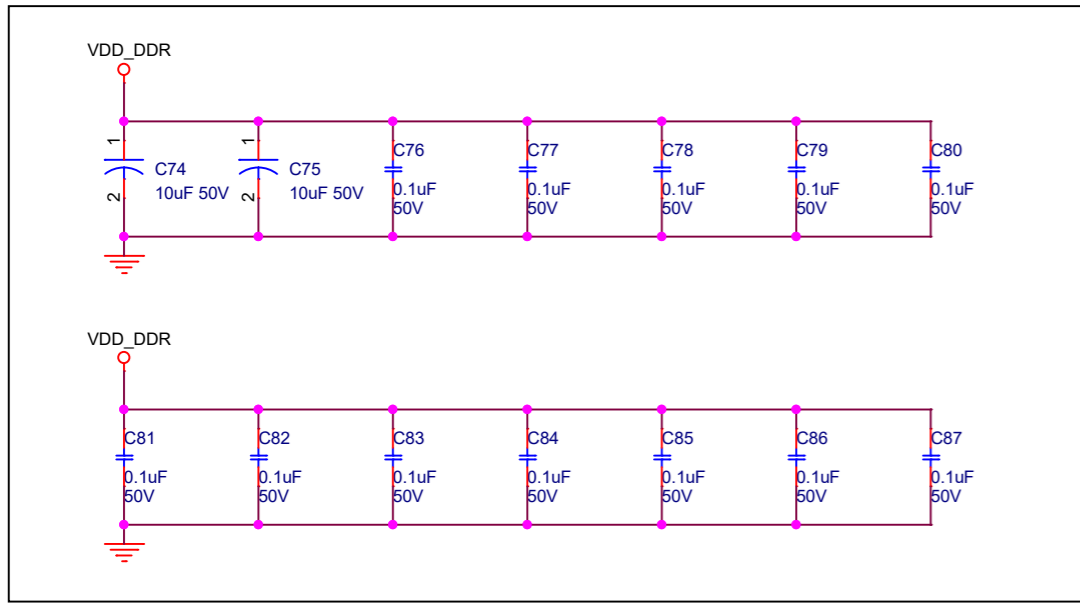

Shiratech Solutions		DDR3		
		SRT-96B-MAIN-IOT-NBIOT-STM-MP157		
Drawn By Moshe Arad	Size A3	CAGE Code <Cage Code>	DWG NO A	Rev 1.1
Wednesday, October 02, 2019	Scale	Sheet 9 of 16		

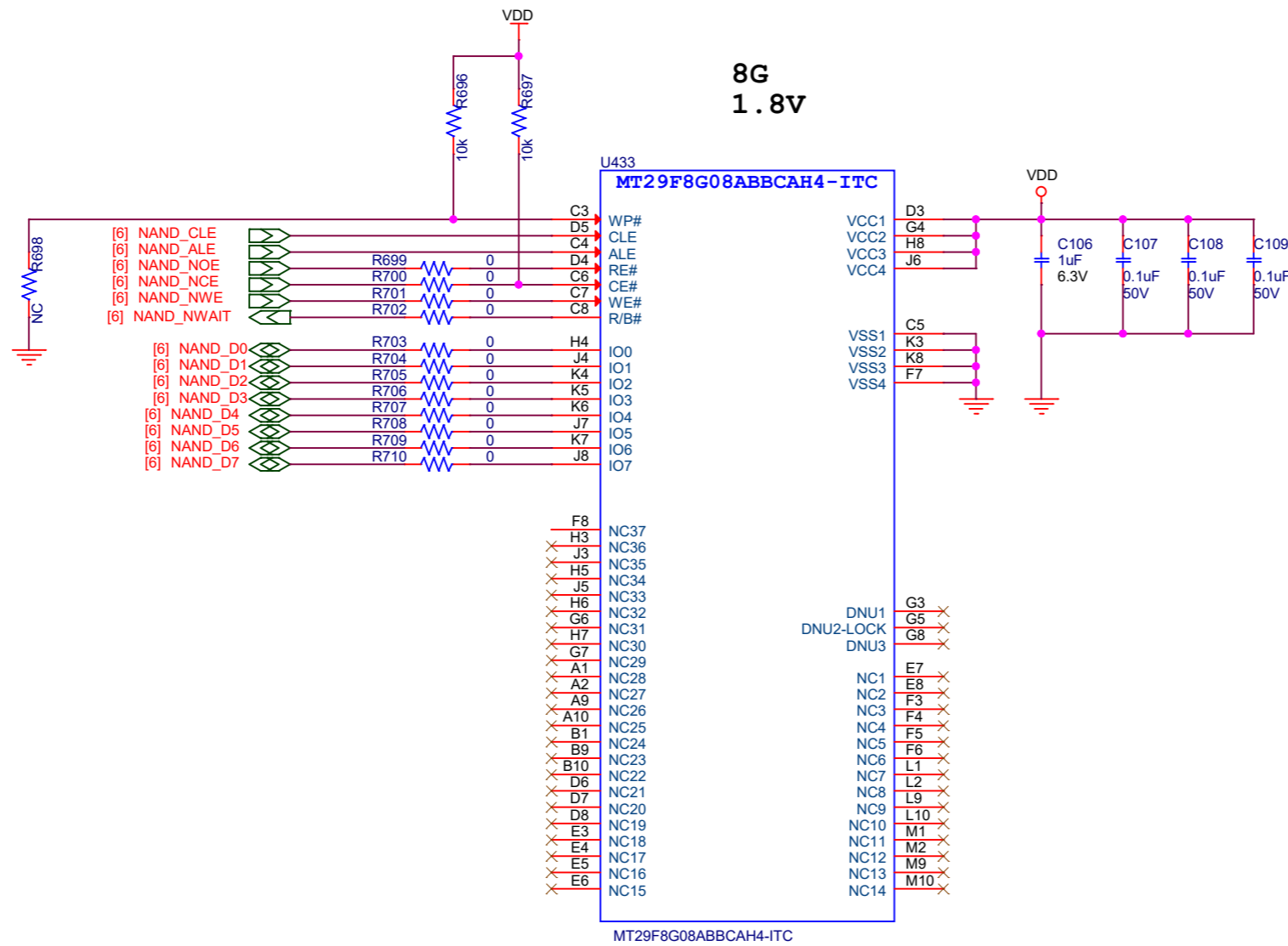

Shiratech Solutions	NAND FLASH		
	SRT-96B-MAIN-IOT-NBIOT-STM-MP157		
Drawn By Moshe Arad	Size A3	CAGE Code <Cage Code>	DWG NO A
Tuesday, September 24, 2019	Scale	Sheet 10 of 16	Rev 1.1

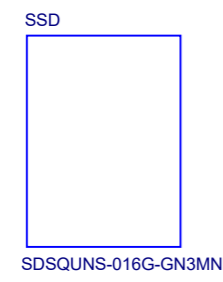
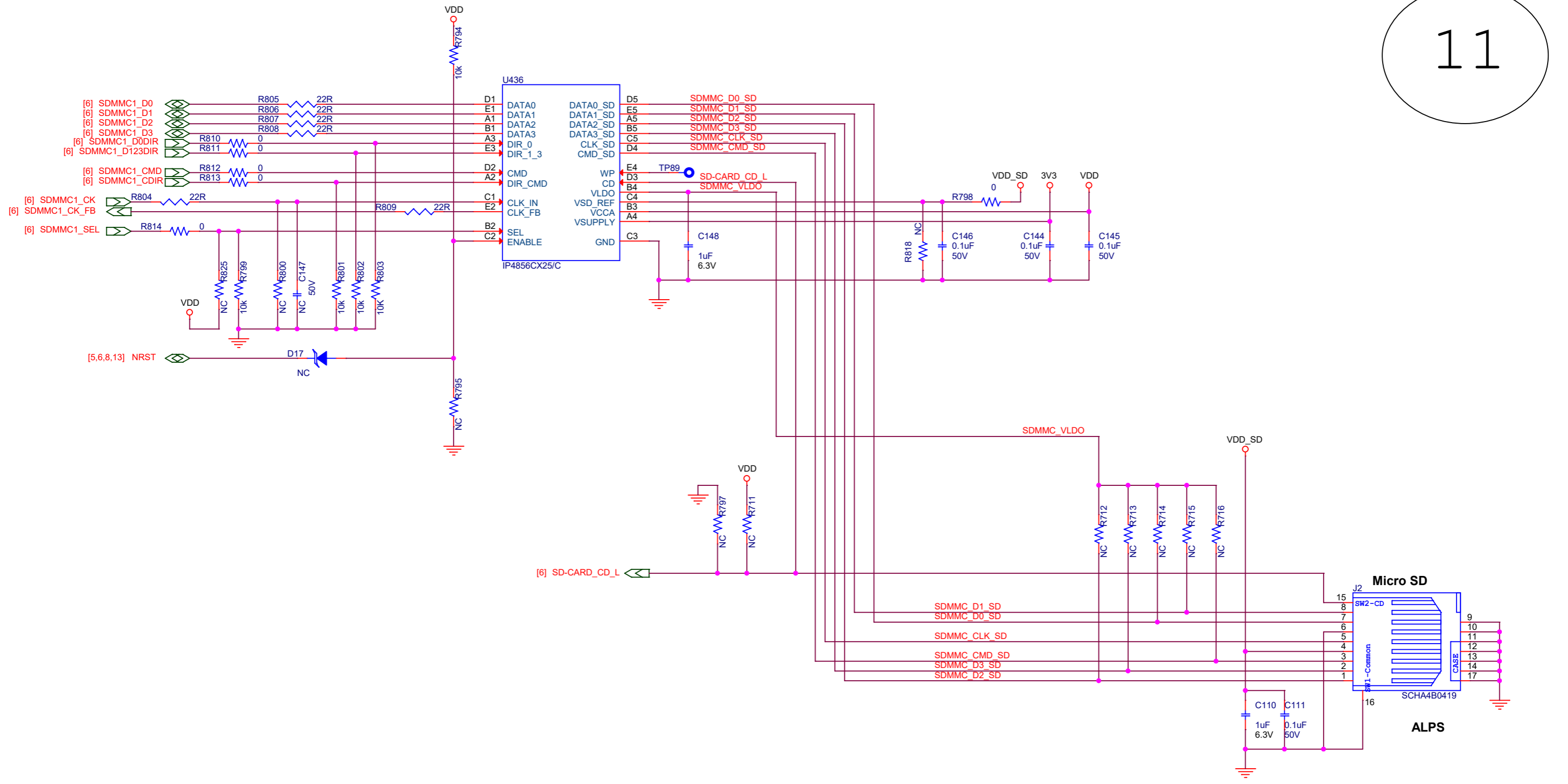

Only for BOM

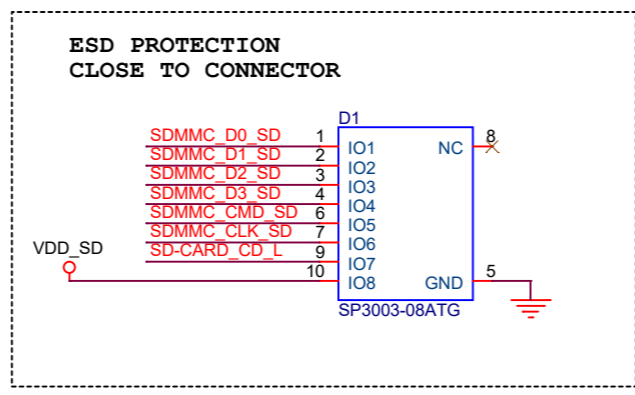

Shiratech Solutions	SD-CARD		
	SRT-96B-MAIN-IOT-NBIOT-STM-MP157		
Drawn By Moshe Arad	Size A3	CAGE Code <Cage Code>	DWG NO A
Tuesday, September 24, 2019	Scale	Sheet 11 of 16	Rev 1.1

1.5A - MAX

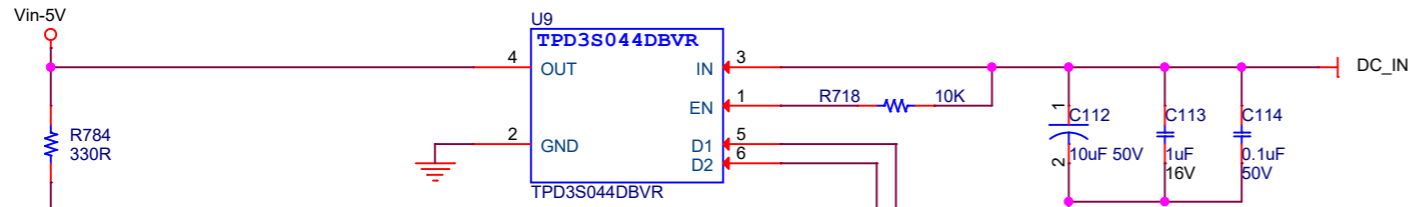

[6] MICRO_USB_DM
[6] MICRO_USB_DP

[6] OTG_VBUS

[6] USB_ID

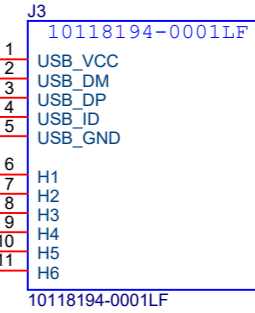

USB/OTG

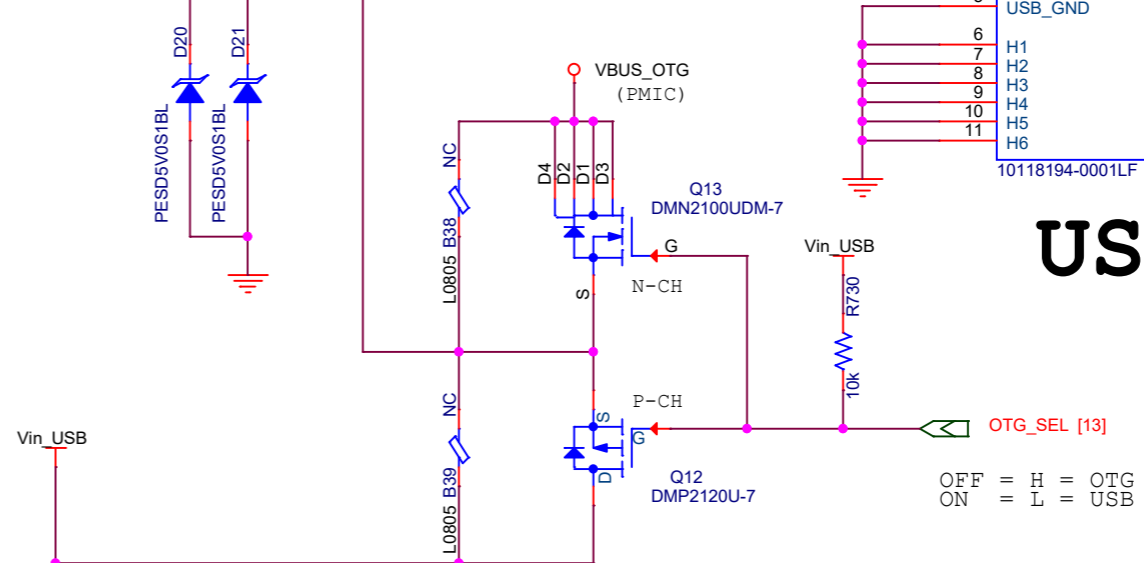

OFF = H = OTG
ON = L = USB

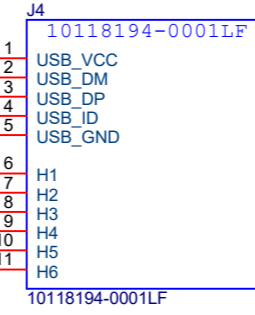
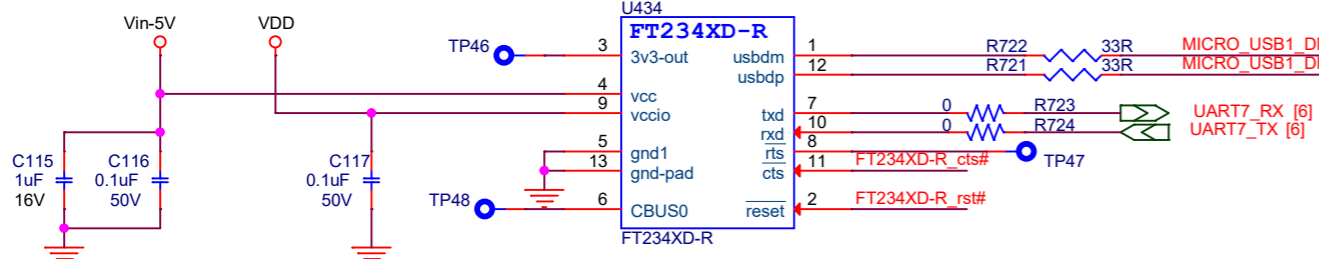

CONSOLE
PWR-IN

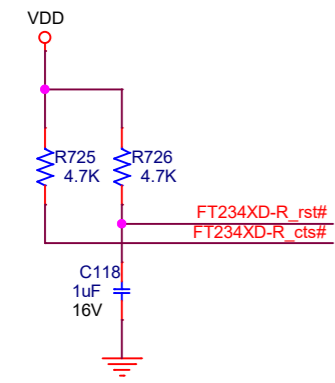

Shiratech Solutions	USB-PORTS		
	SRT-96B-MAIN-IOT-NBIOT-STM-MP157		
Drawn By Moshe Arad	Size A3	CAGE Code <Cage Code>	DWG NO A
Thursday, September 26, 2019	Scale	Sheet 12 of 16	Rev 1.1

Table 2. Boot modes

BOOT2	BOOT1	BOOT0	Initial boot mode	Comments
0	0	0	UART and USB ⁽¹⁾	Wait incoming connection on: – USART2/3/6 and UART4/5/7/8 on default pins – USB high-speed device ⁽²⁾
0	0	1	Serial NOR Flash ⁽³⁾	Serial NOR Flash on QUADSPI ⁽⁴⁾
0	1	0	eMMC ⁽³⁾	eMMC on SDMMC2 (default) ⁽⁴⁾⁽⁵⁾
0	1	1	NAND Flash ⁽³⁾	SLC NAND Flash on FMC
1	0	0	Reserved (NoBoot)	Used to get debug access without boot from Flash memory
1	0	1	SD card ⁽³⁾	SD card on SDMMC1 (default) ⁽⁴⁾⁽⁵⁾
1	1	0	UART and USB ⁽¹⁾⁽³⁾	Wait incoming connection on: – USART2/3/6 and UART4/5/7/8 on default pins – USB high-speed device on OTG_HS_DP/DM pins ⁽²⁾
1	1	1	Serial NAND Flash ⁽³⁾	Serial NAND Flash on QUADSPI ⁽⁴⁾

1. can be disabled by OTP settings.
2. USB requires 24 MHz HSE clock/crystal if OTP is not programmed for different frequency.
3. Boot source can be changed by OTP settings (e.g. initial boot on SD card, then eMMC with OTP settings).
4. Default pins can be altered by OTP.
5. Alternatively, another SDMMC1 or SDMMC2 interface than this default can be selected by OTP.

ST-LINK

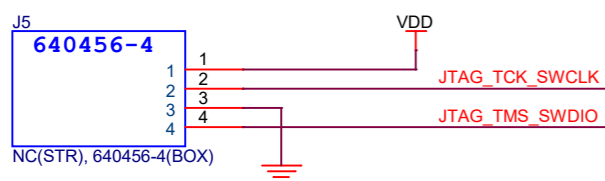

JTAG

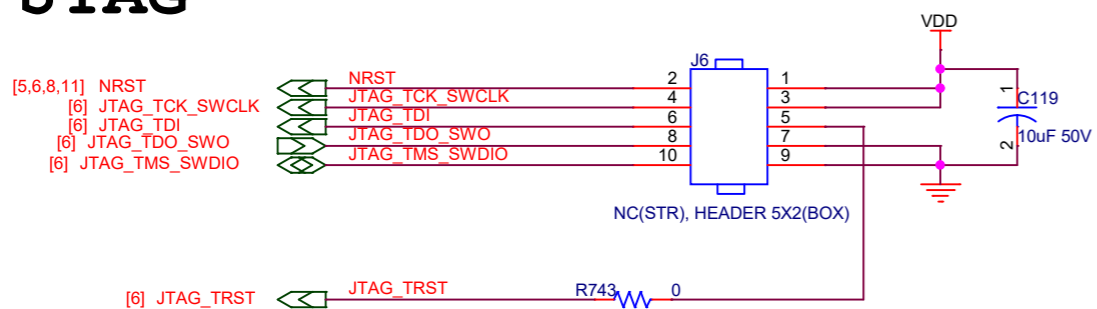

BOOT MODE SEL

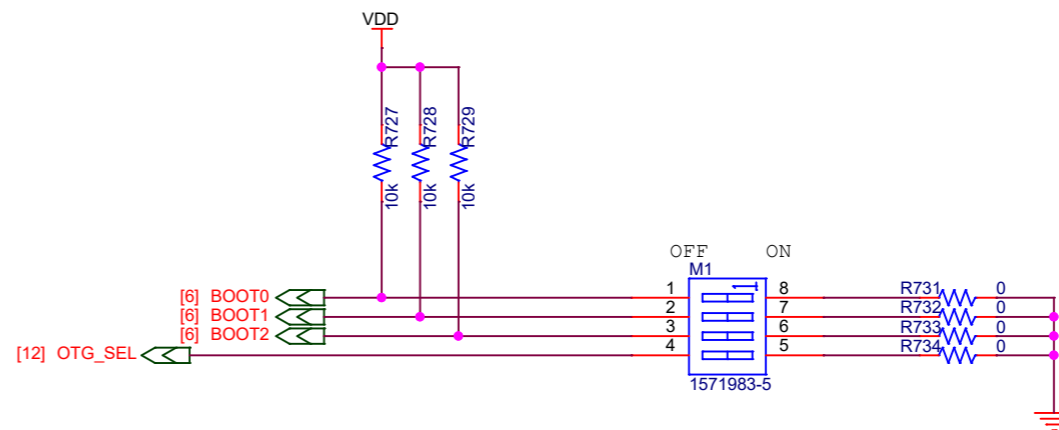

USER_LED1

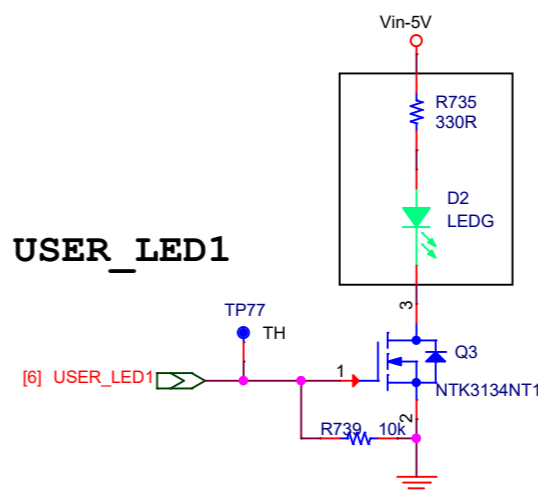

USER_LED2

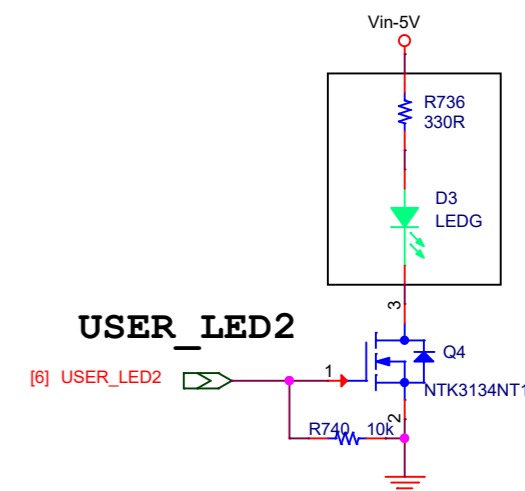

USER_LED3

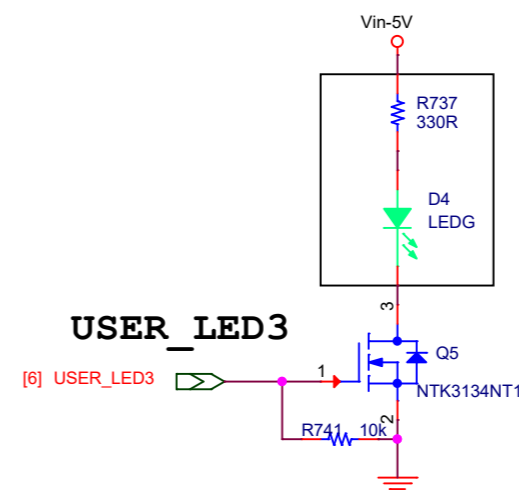

USER_LED4

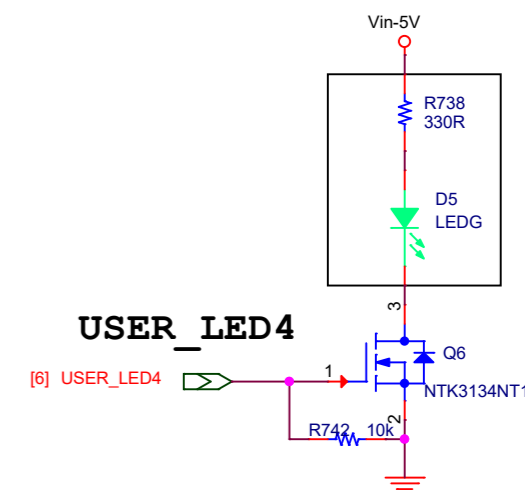

Shiratech Solutions	Peripherals (LEDS, JTAG)		
	SRT-96B-MAIN-IOT-NBIOT-STM-MP157		
Drawn By Moshe Arad	Size A3	CAGE Code <Cage Code>	DWG NO A
Tuesday, September 24, 2019	Scale	Sheet 13 of 16	Rev 1.1

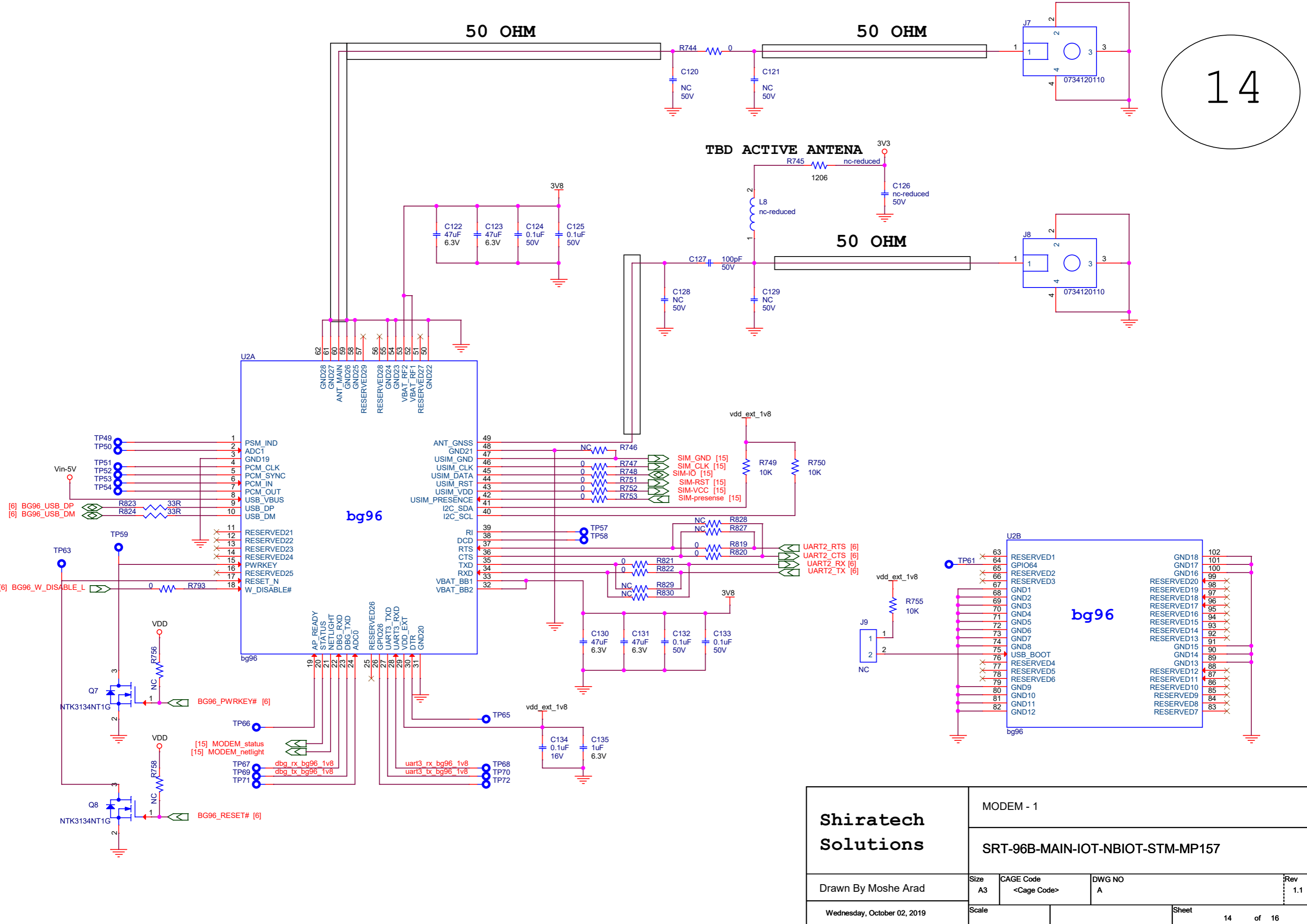

Shiratech Solutions	MODEM - 1		
	SRT-96B-MAIN-IOT-NBIOT-STM-MP157		
Drawn By Moshe Arad	Size A3	CAGE Code <Cage Code>	DWG NO A
Wednesday, October 02, 2019	Scale		Rev 1.1
		Sheet	14 of 16

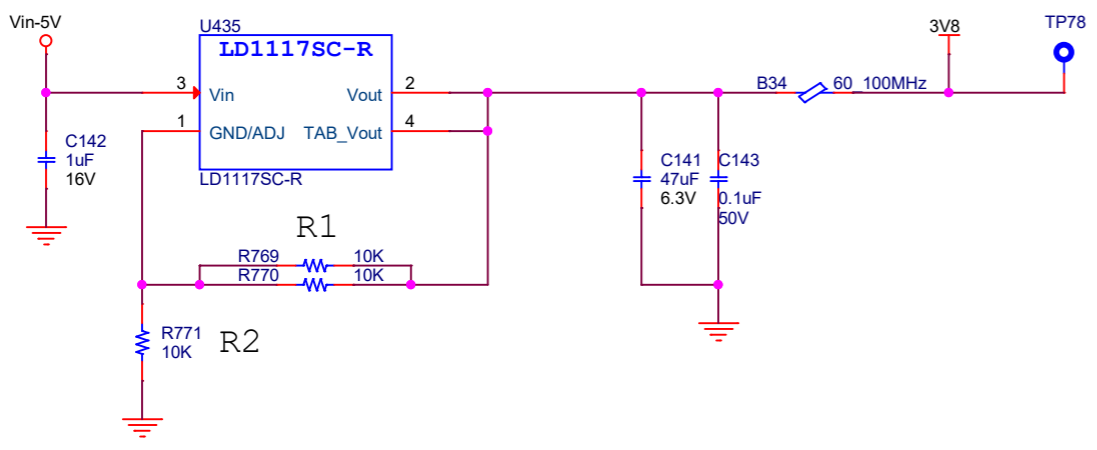
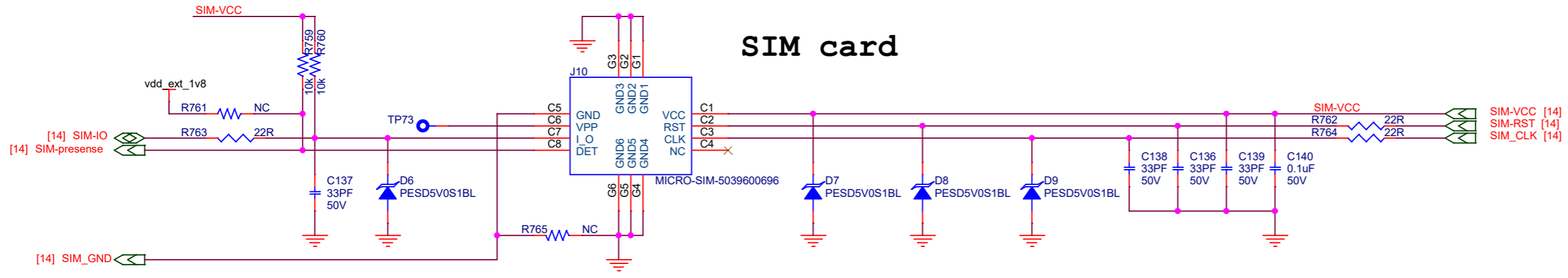

$V_{out} = 1.25(1+R2/R1)$

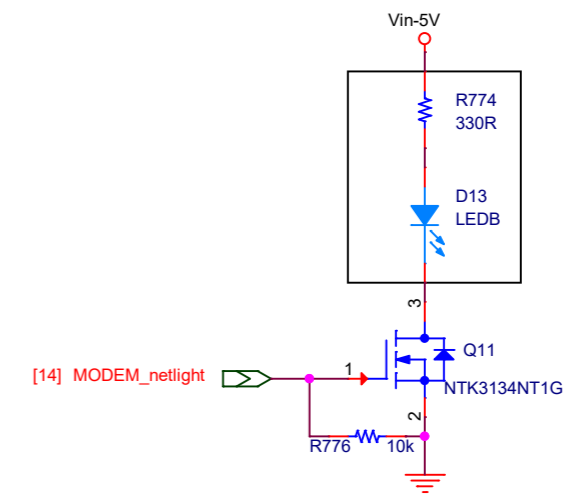
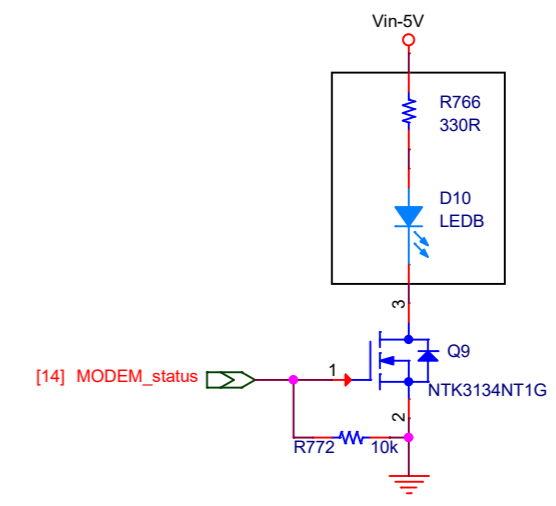

Shiratech Solutions	MODEM - 2		
	SRT-96B-MAIN-IOT-NBIOT-STM-MP157		
Drawn By Moshe arad	Size A3	CAGE Code <Cage Code>	DWG NO A
Tuesday, September 24, 2019	Scale	Sheet 15 of 16	Rev 1.1

LEFT FOR MISC AND FUTURE REMARKS

16

Shiratech Solutions	MISC			
	SRT-96B-MAIN-IOT-NBIOT-STM-MP157			
Drawn By Moshe Arad	Size A3	CAGE Code <Cage Code>	DWG NO A	Rev 1.1
Tuesday, September 24, 2019	Scale		Sheet	16 of 16