

# Carrier Board User manual

## V1.0

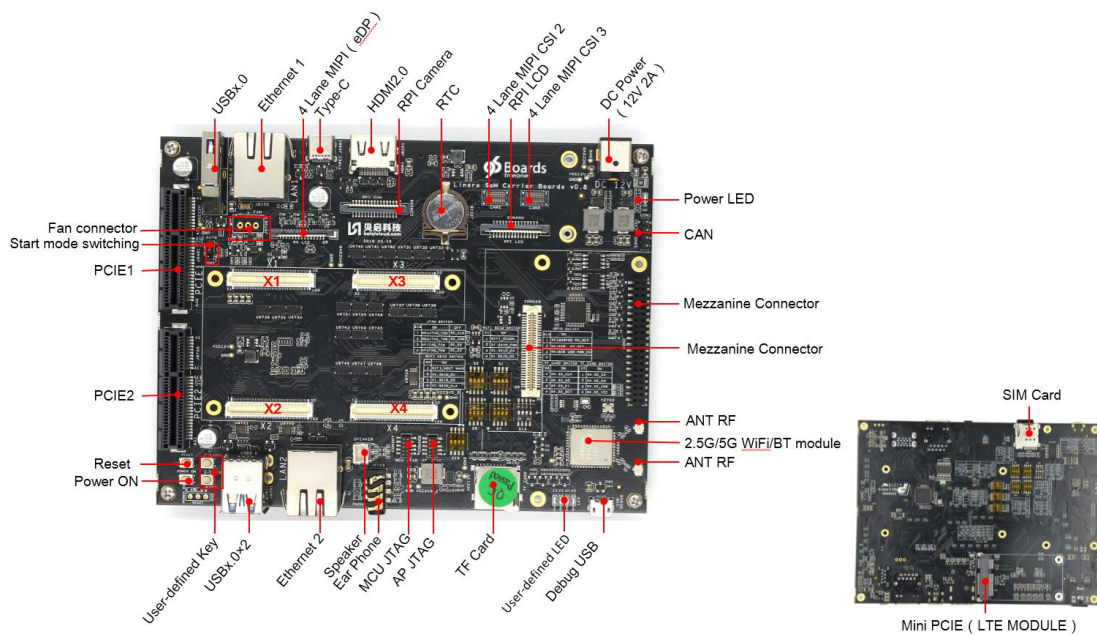

Version	Revision Date	Revised Contents
V1.0	2019-05-08	First version officially released

# 1 Summary Description

96Board Carrier Board is an Interface debugging and testing carrier board. According “96Boards Compute SoM Edition Hardware Platform Specification” and “96Boards Enterprise Edition Server Hardware Platform Specification”.This carrier board provides many interface as possible to meet the needs of Som board debugging an testing.

Now ,this Carrier Board already be adapted to TB-96AI SOM and TB-96AIoT SOM boards.

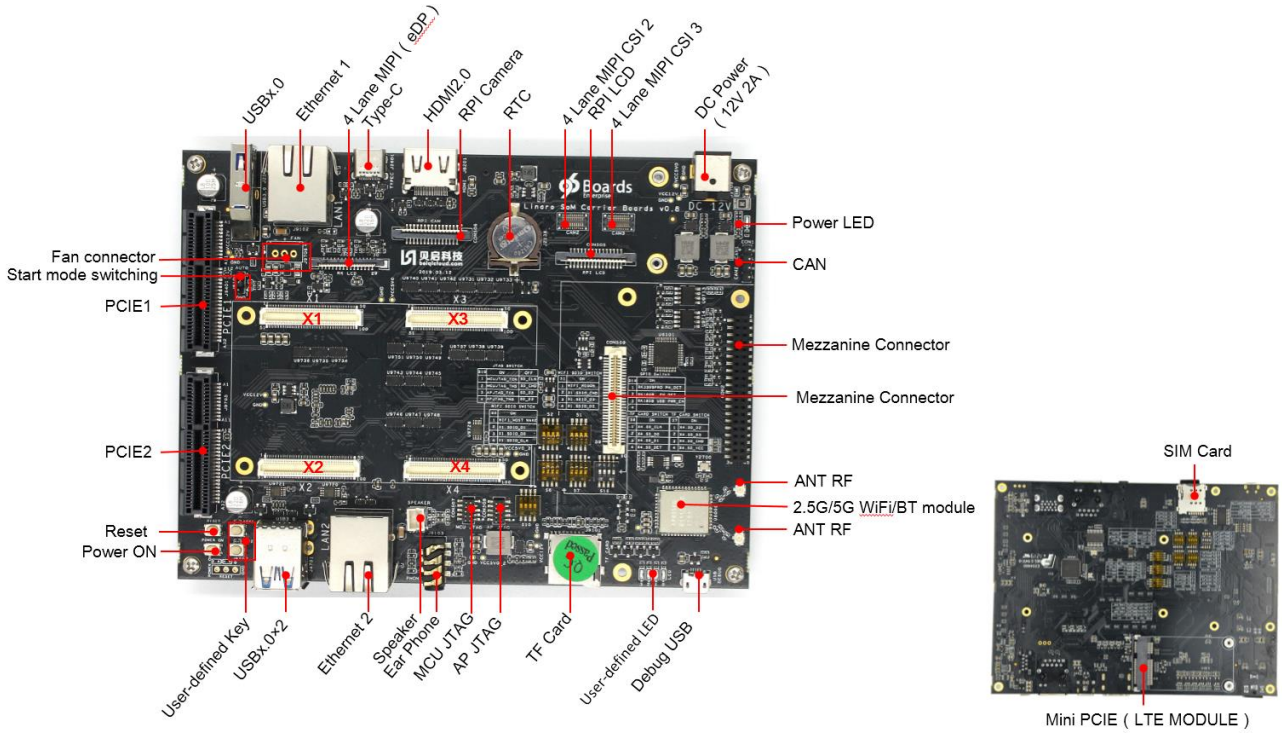

# 2 Interface Introduction

Interface definition	Description
DC Power ( 12V 2A )	Power supply $\phi$ 5.5mm DC Connector
4 Lane MIPI CSI2	Camera interface for MIPI_RX1 on TB-96AI RK3399Pro Som 4 Lane MIPI CSI AXT530124 on Board
4 Lane MIPI CSI3	Camera interface for MIPI_RX in TB-96AIoT RK1808 Som 4 Lane MIPI CSI AXT530124 on board
RPI LCD	Raspberry Pi MIPI LCD Connector for TB-96AI RK3399Pro Som and TB-96AIoT RK1808 Som,1-1734248-5 on board
RTC	RTC battery holder
RPI Camera	Raspberry Pi Camera Connector for MIPI_RX0 in TB-96AI RK3399PRO Som, 1-1734248-5 on board
4 Lane MIPI ( eDP )	eDP connector for TB-96AI RK3399Pro Som,MIPI connector for TB-96AIoT RK1808 Som, defined by Rockchip
Ethernet 1	1000Mbps Ethernet Port for TB-96AI RK3399PRO Som

Ethernet 2	1000Mbps Ethernet Port for TB-96AIoT RK1808 Som
USBx.0	USB3.0 for TB-96AI RK3399Pro Som
USBx.0*2	USB3.0 for TB-96AI RK3399Pro,USB2.0 for TB-96AIoT RK1808 Som
Fan Connector	Fan connector
Start mode Switching	Auto Start mode selection
PCIE	PCIE x4 interface
Reset key	Reset key
Power ON Key	Press the sleep or wake up, long press to power down and power on
User-Defined Key	The buttons function for User define self
Speaker	8 Ω 1W Speaker interface
Phone	Earphone interface
MCU JTAG	MCU JTAG interface
AP JTAG	AP JTAG interface
TF Card	TF Card interface
USER-Defined LED	User-defined leds
Debug	Debug usb,USB to UART chip FT232RL on board
2.4G/5G Wifi/BT module	Wifi/BT module AP6356S
ANT RF	WIFI/BT Antenna interface
Mezzanine Connector	Mezzanine Connector,contains high speed connector and low speed connector
CAN	CAN interface
System LED	System LED
X1、X2、X3、X4	Som board Connector

### 3 MUX SWITCH Description

The Carreier Board has 15 mux Switch. These Switchs can control many high speed buses connect to different Connectors.

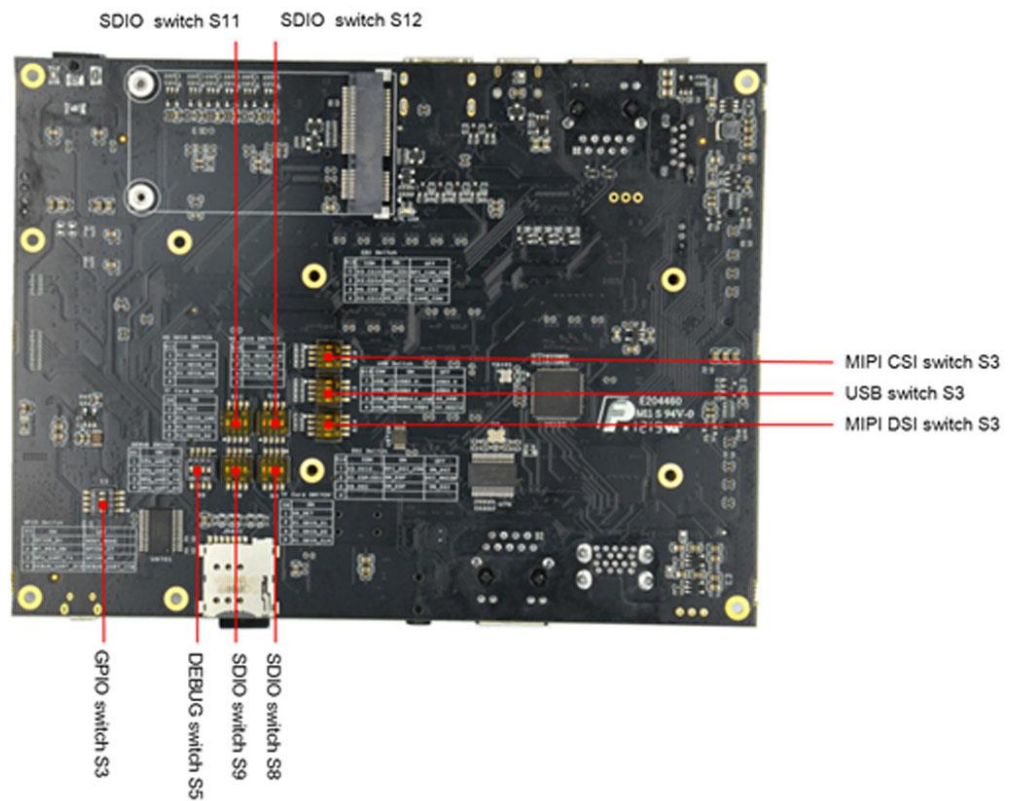
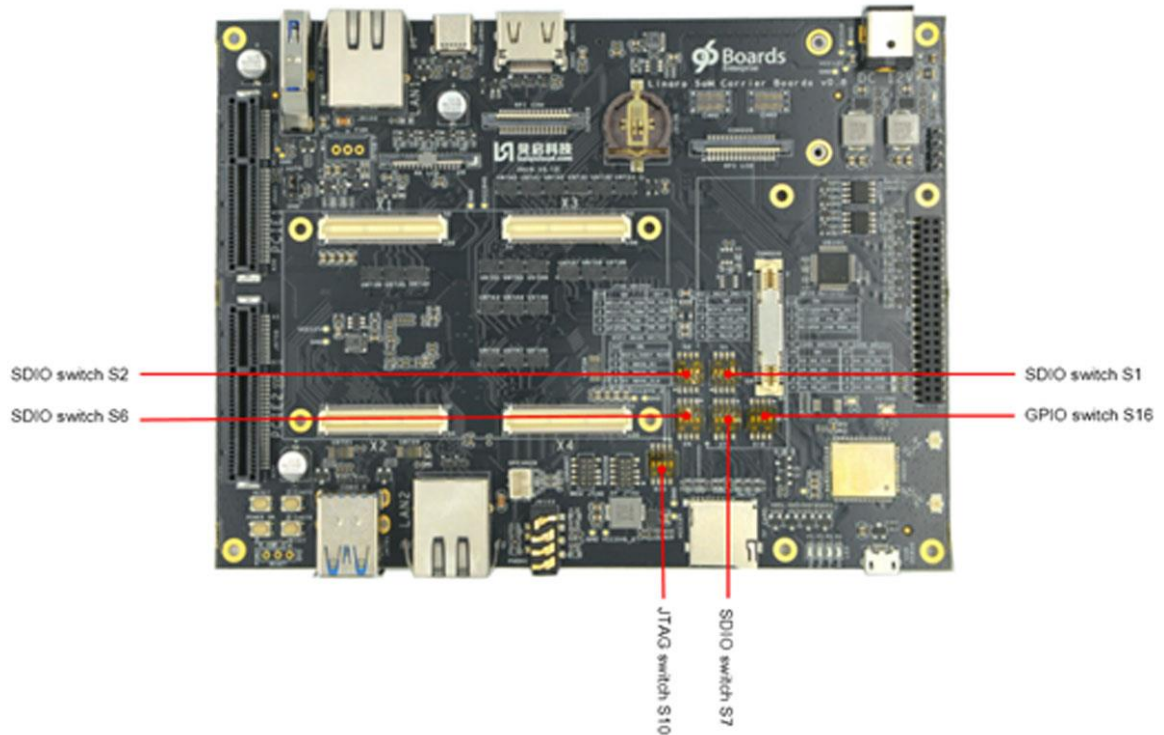

### 3.1 SDIO Switches

S1,S2,S6,S7,S8,S9,S11,S12 are the SDIO control switches.

Switches on S1 and S2 connect the SDIO on X1 to the WIFI module AP6356S on the carrier board.

Switches on S8 and S9 connect the SDIO on X1 to the TF card connector on the carrier board

Switches on S6 and S7 connect the SDIO on X4 to the TF card connector on the carrier board

Switches on S11 and S12 connect SDIO on X1 to the high speed expansion connector for Mezzanine Boards.

It should be noted that, S1, S2, S8, S9, S11, S12 can only be turned on one set the same time, while the other two sets of switches must be turned off.S8,S9,S6,S7 also can only be turned on one set.

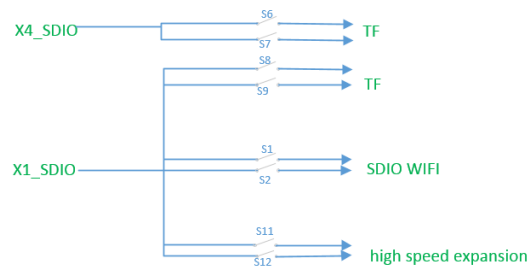

WIFI SDIO SWITCH							
S1	COM	ON	OFF	S2	COM	ON	OFF
1	X1_GPIO2_D4/GPIO0_B3	WIFI_REGON	OFF	1	X1_GPIO2_D2/GPIO0_A3	WIFI_HOST WAKE	OFF
2	X1_SDIO0_CMD	WIFI_SDIO_CMD	OFF	2	X1_SDIO0_D1	WIFI_SDIO_D1	OFF
3	X1_SDIO0_D3	WIFI_SDIO_D3	OFF	3	X1_SDIO0_D0	WIFI_SDIO_D0	OFF
4	X1_SDIO0_D2	WIFI_SDIO_D2	OFF	4	X1_SDIO0_CLK	WIFI_SDIO_CLK	OFF

high speed expansion SDIO SWITCH							
S11	COM	ON	OFF	S12	COM	ON	OFF
1	X1_SDIO0_D2	HS_SDIO_D2	OFF	1	X1_SDIO0_CLK	HS_SDIO_CLK	OFF
2	X1_SDIO0_D3	HS_SDIO_D3	OFF	2	X1_SDIO0_D0	HS_SDIO_D0	OFF
3	X1_SDIO0_CMD	HS_SDIO_CMD	OFF	3	X1_SDIO0_D1	HS_SDIO_D1	OFF
4				4			

TF Card SWITCH							
S8	COM	ON	OFF	S9	COM	ON	OFF
1	X1_GPIO2_D2/GPIO0_A3	SD_DET	OFF	1	VCC3V3_SYS_S3	VCC3V3_SD_S0	OFF
2	X1_SDIO0_D1	SDIO_D1	OFF	2	X1_SDIO0_CMD	SDIO_CMD	OFF
3	X1_SDIO0_D0	SDIO_D0	OFF	3	X1_SDIO0_D3	SDIO_D3	OFF
4	X1_SDIO0_CLK	SDIO_CLK	OFF	4	X1_SDIO0_D2	SDIO_D2	OFF
TF Card SWITCH							
S6	COM	ON	OFF	S7	COM	ON	OFF



1	X4_SDMMC0_CLK	SD_CLK	OFF	1	X4_SDMMC0_D2	SD_D2	OFF
2	X4_SDMMC0_D0	SD_D0	OFF	2	X4_SDMMC0_D3	SD_D3	OFF
3	X4_SDMMC0_D1	SD_D1	OFF	3	X4_SDMMC0_CMD	SD_CMD	OFF
4	X4_SDMMC0_DET_L	SD_DET	OFF	4			

### 3.2 Debug Switches

S5,S10 are the Debug switches.

There is a USB serial port chip FT232RL on Carrier board. The users only need connect a micro usb cable to the PC to start debugging. The RK3399Pro have two debug uart, one for cpu, the other one for npu. When turn on the bit1 and bit2 on S5, the debug usb is connect to the cpu uart. When turn on the bit3 and bit4, the debug usb is connect to npu uart.

The S10 is a switch for JTAG. The JTAG is muxed on the TF card interface. When use the JTAG, the the switches for SDIO must connect to TF card. Turn on the S10 at the same time.



DEBUG SWITCH			
S5	COM	ON	OFF
1	X1_UART2_TX_DEBUG	FT232RL_RX	OFF
2	X1_UART2_RX_DEBUG	FT232RL_TX	OFF
3	X4_NPU_UART2_TX	FT232RL_RX	OFF
4	X4_NPU_UART2_RX	FT232RL_TX	OFF

JTAG SWITCH			
S10	COM	ON	OFF
1	X4_SD_CLK	MCUJTAG_TCK	OFF
2	X4_SD_CMD	MCUJTAG_TMS	OFF
3	TF_SD_D2	APJTAG_TCK	OFF
4	TF_SD_D3	APJTAG_TMS	OFF

### 3.3 GPIO Switches

Different Som has different GPIO resource,so the carrier board must have different GPIO config.

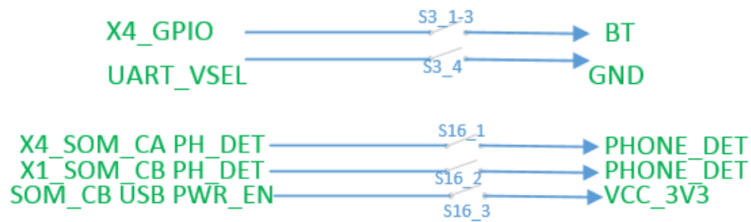

GPIO SWITCH			
S3	COM	ON	OFF
1	X4_GPIO0_B1	BT_HOST_WAKE	
2	X4_GPIO4_C6	BT_WAKE	
3	X4_PCIE1_PWR_EN/GPIO0_A6	BT_REG_ON	
4	UART_VSEL	UART_3V3	UART_1V8

  

GPIO SWITCH			
S16	COM	ON	OFF
1	X4_RK3399PRO PH_DET	PHONE_DET	
2	X1_RK1808 PH_DET	PHONE_DET	
3	RK1808 USB PWR_EN	VCC3V3_SYS_S3	
4			

### 3.4 USB Switches

TB-96AI RK3399Pro Som has an USB3.0 host, but the TB-96AIoT RK1808 Som only has USB2.0. so the carrier board has a USB3.0 hub chip and a USB2.0 hub chip. The TB-96AI RK3399Pro Som can use all two hubs, TB-96AIoT RK1808 Som only can use USB2.0 hub.

The carrier board use the FSUSB30MUX chip to switch the USB buses. User can control the FSUSB30MUX chips through the S13.

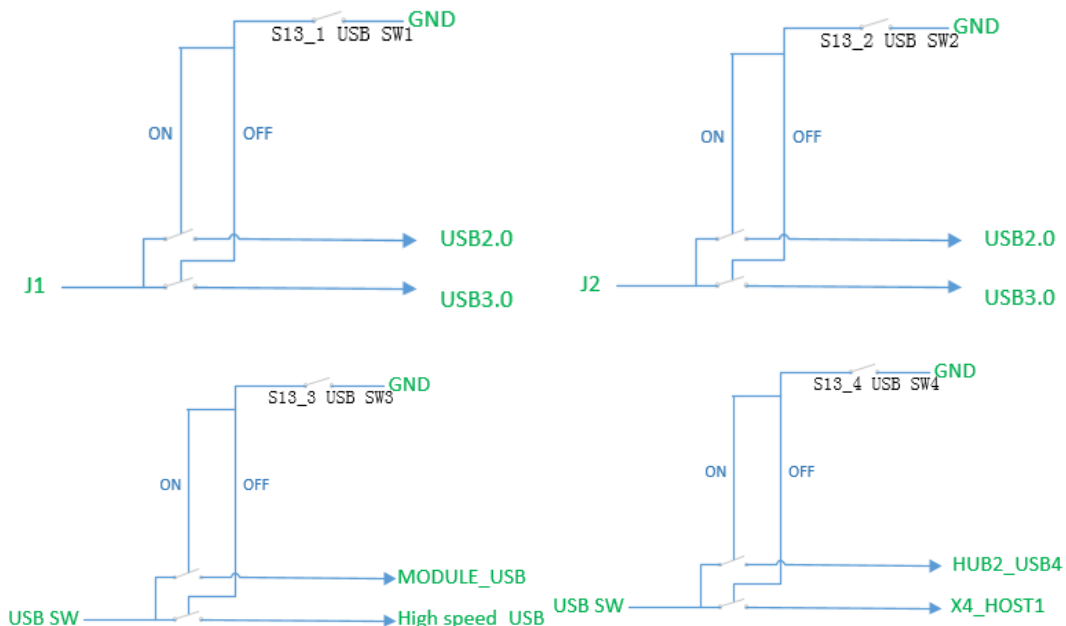

USB SWITCH			
S13	COM	ON	OFF
1	USB_J1	USB2.0	USB3.0
2	USB_J2	USB2.0	USB3.0
3	USB_SW	MODULE_USB	HS_USB
4	USB_SW	HUB2_USB4	X4_host1

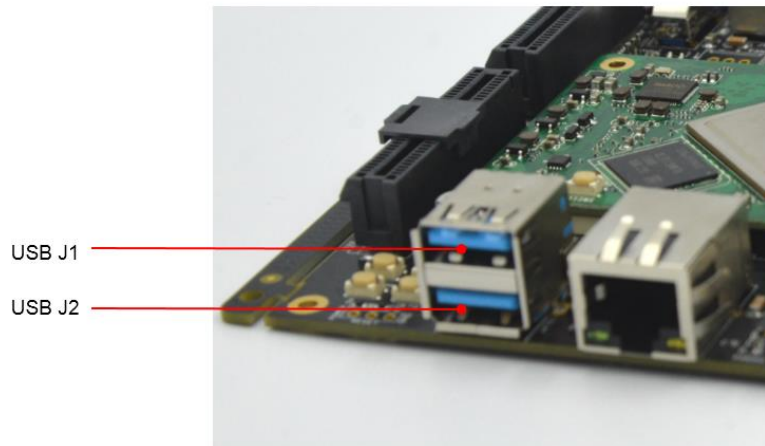

### 3.5 MIPI DSI Switches

The carrier board has one mipi DSI/edp connector defined by Rockchips,one Raspberry Pi 7" MIPI LCD connector.So it need some high speed switche chips.The carrier boards use some hd3ss3212 to switch the mipi bus.User can control the hd3ss3212 chips through S14.

DSI SWITCH			
S14	COM	ON	OFF
1	X3_DSI2	RPI_DSI_CON	SW_DSI
2	X1_EDP/DSI	SW_EDP	DSI_RKCON
3	HS_DSI	SW_EDP	SW_DSI
4			

### 3.6 MIPI CSI Switches

The carrier board has two mipi CSI connector defined by Rockchips,one Raspberry Pi Camera connector. At the same time,high-speed connectors also need CSI .The carrier boards also use some hd3ss3212 to switch the mipi CSI bus.

CSI SWITCH			
S15	COM	ON	OFF
1	X3_CSI0	SW1_CSI	RPI_CSI
2	X2_CSI4	SW2_CSI	RK_CAM3
3	HS_CSI0	SW2_CSI	SW1_CSI
4	X3_CSI1	HS_CSI1	RK_CAM2